

# Operating instructions for "No-frost" freezer

**GB**

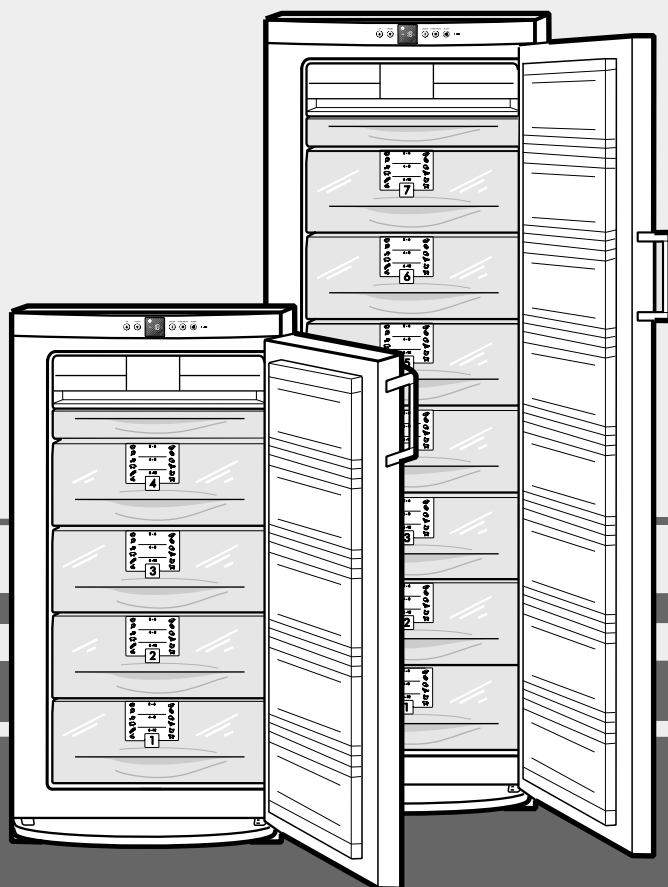

7081 808-01

GSN/GSND/GSNP...6 2103

# The appliance at a glance

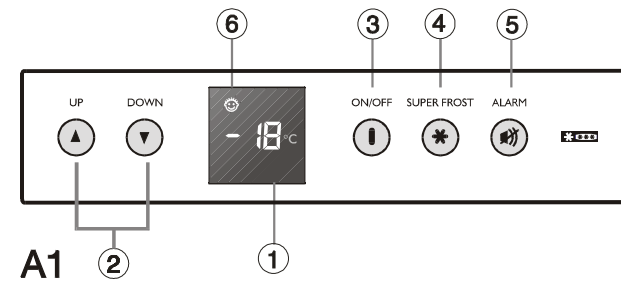

## Operating and control elements fig. A1

- ① Temperature display and setting display
- ② Temperature buttons: **UP = higher, DOWN = lower**, recommended setting: -18°C
- ③ On/off button
- ④ Superfrost button lit = function activated  
For fast freezing of fresh food:
  - Press the Superfrost button ④ briefly so that it lights up.
  - The freezer will take approx. 6 - 24 hours to reach its lowest temperature.
  - Place the fresh food in the top drawers.
  - The Superfrost function is switched off **as required**. The freezer will switch back automatically to normal operation.
- ⑤ Audible warning on/off button
- ⑥ Child-proof lock display  
Prevents the appliance from being switched off accidentally.
  - Hold down the audible warning on/off button and then press the Superfrost button and keep both buttons pressed for about 3 seconds. A short double beep will sound and the display ⑥ will light up; the child-proof lock is now active.
  - To switch off: press this key combination again; the display will go off.

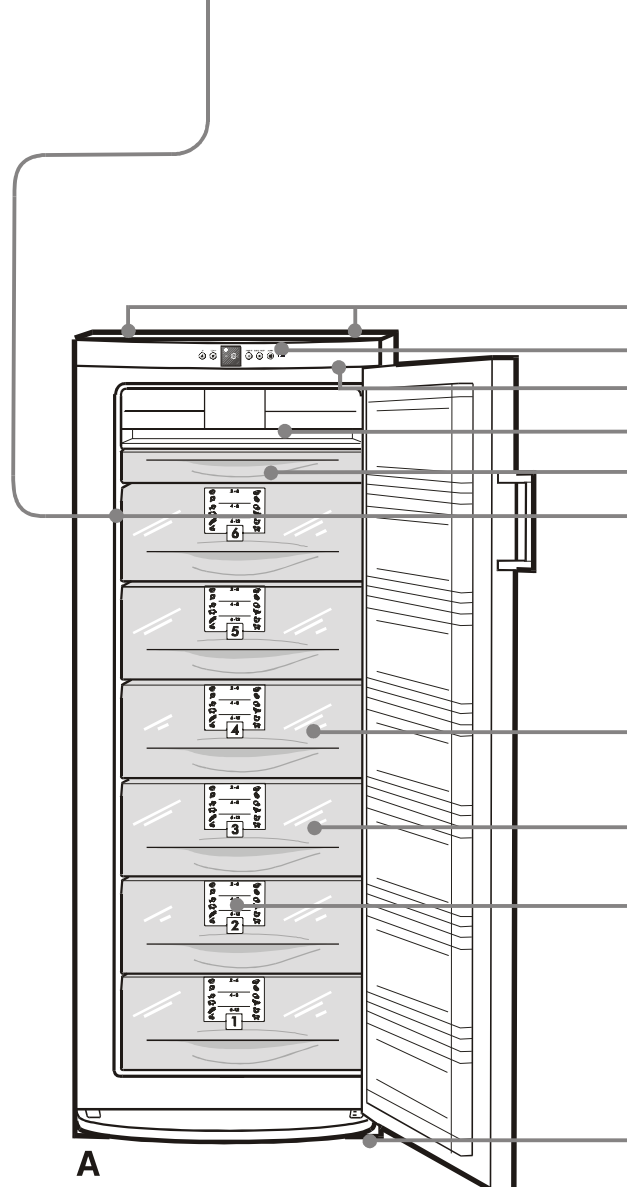
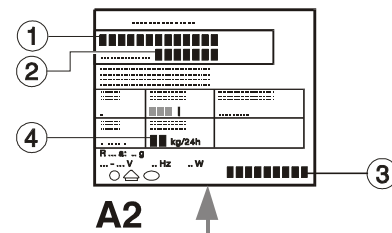

## Description of appliance and equipment fig. A

- Rear transport grips
- Operating and control elements
- Lighting
- "No-frost" device for automatic defrosting
- Freezer tray\*, cold-storage accumulator\*
- Type/Data plate, fig. A2
  - ① Type designation
  - ② Service number
  - ③ Appliance number
  - ④ Freezing capacity in 24 hours
- Drawers with information system\*
- Vario-Space thanks to removable intervening shelves\*
- Ice-cube tray\*
- Adjustable-height feet, front transport grips, transport castors at back

Congratulations on your purchase. In choosing this appliance you have opted for all the benefits of state-of-the-art refrigeration technology, guaranteeing you top quality, a long life span and excellent reliability. The features on your appliance have been designed to ensure maximum convenience - day in, day out. This appliance has been manufactured with recyclable materials using an environmentally friendly process, so together you and we are making an active contribution to the preservation of our environment. To get to know all the benefits of your new appliance, please read the information contained in these operating instructions carefully. We wish you much pleasure with your new appliance.

Before reading, please fold out and refer to the illustrated front page.

Keep these operating instructions in a safe place and pass them on to the next owner, where applicable.

The operating instructions apply to several models. Differences may therefore occur.

## Contents Page

<b>Operating instructions</b>	
The appliance at a glance .....	10
Contents .....	10
1 Safety instructions and warnings .....	11
Disposal notes .....	11
Setting up .....	11
2 Operation and control elements .....	12
Safety regulations .....	12
Connecting to the mains .....	12
Switching the appliance on and off .....	12
Setting the temperature .....	12
Child-proof lock .....	12
Temperature display .....	13
Audible warning signal .....	13
Power failure/"frost-control" display .....	13
Lighting .....	13
3 Superfrost .....	14
Notes on freezing and storage .....	14
4 Equipment .....	15
Information system .....	15
Freezer tray .....	15
Cold-storage accumulators .....	15
Making ice-cubes .....	15
Vario-Space* .....	15
5 Defrosting .....	16
Cleaning .....	16
Energy savings .....	16
6 Troubleshooting .....	16
Customer service and type plate .....	16
<b>Instructions for installation and modification</b>	
Dimensions .....	17
Changing over door hinges .....	17

\* Depending on model and options

# 1 Safety instructions and warnings



## Disposal notes

The **packaging** is designed to protect the appliance and individual components during transport and is made of recyclable materials.

- Corrugated board/board
- Moulded polystyrene (foamed, CFC-free polystyrene)
- Polythene bags and sheets
- Polypropylene straps
- **Keep packaging materials away from children - polythene sheets and bags can suffocate!**
- Please return the packaging material to your nearest official collection point so that the various materials can be reused or recycled as far as possible.

## Your old appliance:

This contains some reusable materials and should not simply be disposed of with household or bulk refuse.

- Disable discarded appliances immediately by removing the plug and cutting through the connection cable.
- Remove the spring-action or bolt catch from the appliance or render it unusable so that children cannot become trapped inside and suffocate.**
- Ensure that the refrigerant circuit is not damaged before the appliance that is no longer needed is taken away for disposal. In this way the refrigerant or oil will not escape into the environment.
- Exact details of the refrigerant used can be found on the type plate. The heat insulator is PU with Pentane.
- Information on collection dates or collection points can be obtained from the waste disposal authorities or local council.

## Technical safety



- To prevent injury or damage to the unit, the appliance should only be transported wrapped and set up by two people.
- The refrigerant R 600a is environmentally friendly but flammable.
- Do not damage the refrigerant circuit pipes. Splashes of refrigerant can harm your eyes or ignite.
- If refrigerant escapes, remove all naked flames or sources of ignition in the vicinity of the leak, disconnect the appliance from the mains and ventilate the area well.
- In the event that the appliance is damaged, contact the supplier immediately before connecting to the mains.
- To guarantee safe operation, ensure that the appliance is set up and connected as described in these operating instructions.
- Disconnect the appliance from the mains if any fault occurs. Pull out the plug (not by pulling on the mains cable) or switch off or remove the fuse.
- **Any repairs and work on the appliance should only be carried out by the customer service department, as unauthorised work could prove highly dangerous for the user.** The same applies to changing the mains power cable.



## Safety during use

- Do not store explosives or sprays using combustible propellants such as butane, propane, pentane, etc. in the appliance. Electrical components might cause leaking gas to ignite. You can identify such sprays by the printed contents or a flame symbol.
- Only store high-percentage alcohol in tightly sealed, upright containers.
- Do not allow naked flames or ignition sources to enter the appliance.
- Do not use electrical appliances inside the appliance (e.g. steam cleaners, heaters, ice makers, etc.).
- Do not stand on the plinth, drawers or doors or use them to support anything else.
- Do not let children play with the appliance, e.g. do not allow them to sit in the drawers or swing on the door.
- Do not eat ice-cream, particularly ice lollies or ice-cubes, immediately after taking them from the freezer compartment as there is a risk of "burning" because of the very cold temperatures.
- Do not consume food which has been stored for too long, as it could cause food poisoning.

## Setting up



- When setting up/fitting ensure that the refrigerant circuit pipes are not damaged.
- Once in position, use the 10 spanner provided to adjust the feet so that the appliance is level and does not wobble.
- Avoid positioning in direct sunlight or next to an oven, radiator or similar, in damp locations or near spraying water.
- The basement is an ideal site for installation.
- Standard EN 378 specifies that the room in which you install your appliance must have a volume of 1 m<sup>3</sup> per 8 g of R 600a refrigerant used in the appliance, so as to avoid the formation of inflammable gas/air mixtures in the room where the appliance is located in the event of a leak in the refrigerant circuit. The quantity of refrigerant used in your appliance is indicated on the type plate on the inside of the appliance.
- **The ventilation grilles should not be obstructed. Always ensure that there is good ventilation and that the outward flowing air is able to escape.** Please note the appendix concerning installation instructions.
- Do not place heat-emitting appliances, e.g. microwave oven, toaster, etc., on top of the refrigerator or freezer.
- When you open the door for the first time, the handle\* switches from the transport position to the operating position; you will hear a soft click.
- Remove all transportation safety components.

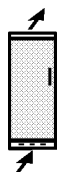

GB

## 2 Operation and control elements

### Safety regulations

§

- The appliance is designed to freeze and store food and to make ice. It is designed as a household appliance. If used commercially, the relevant regulations on commercial use must be observed.
- The appliance is set to operate within specific ambient temperature limits according to its climate rating. These temperature limits should not be exceeded. The correct climate rating for your appliance is indicated on the type plate. This is explained as follows:

Climate rating	Set for ambient temperatures
SN, N	up to +32°C
ST	up to +38°C
T	up to +43°C

- The appliance will function properly in ambient temperatures of down to +5°C.
- The refrigerant circuit has been tested for leaks.
- The appliance complies with current safety regulations and EC directives 73/23/EEC and 89/336/EEC.

You are advised to clean the appliance before switching it on for the first time (see "Cleaning").

Switch on the appliance approx. 4 hours before loading it with frozen food for the first time. Do not load with frozen food until the temperature shows at least -18°C.

### Connecting to the mains

#### Power supply (AC) and voltage

at the operating point must comply with the details on the type plate, which is located inside the appliance on the left, fig. A.



- **Connect the appliance with a properly earthed fused plug and socket only.**
- The socket must be fused with a 10 A fuse or higher, it must be away from the rear of the appliance and must be easily accessible.
- *Do not*
  - connect to stand-alone inverters\*,
  - operate with so-called energy-saving plugs - this can damage the electronic system,
  - connect to the supply with other equipment using an extension cable - risk of overheating.
- When removing the mains cable from the back of the appliance, remove the **cable holder** so as to avoid vibration noise.

The wires in the mains lead are coloured in accordance with the following code: green/yellow = earth, blue = neutral, brown = live.

**Warning! This appliance must be earthed.**

#### Non-rewireable plugs BS 1363

If this machine or appliance is fitted with a non-rewireable plug, the following information applies: If the socket outlets are not suitable for the plug supplied with this product, it must be cut off and an appropriate plug fitted. The plug cut from the flexible cord should be disposed of and on no account be inserted into a 13 A socket elsewhere in the house (electric shock hazard).

The fuse cover **must** be re-fitted when changing the fuse, and if the fuse cover is lost the plug **must not** be used until a suitable replacement is obtained. The colour of the correct replacement cover is that of the coloured insert in the base of the plug, or the colour that is embossed in words on the base of the plug (as applicable to the design of the plug fitted). The correct rating of the replacement fuses that are ASTA approved to BS 1362 should be fitted. Replacement fuse covers may be purchased from your local electrical suppliers, electricity showroom or approved service agent.

### Switching the appliance on and off

fig. A1

ON/OFF



- **Switching on:** Press the on/off button ③ so that the temperature display lights up/flashes.
  - The lighting will light up when the door is open.
  - The alarm will sound when the appliance is switched on for the first time and when the appliance is "warm".
 Press the audible warning on/off button ⑤ to switch it off. See the "Audible warning signal" for more information.
- **Switching off:** Press the on/off button again so that the temperature display goes out.

### Setting the temperature

fig. A1

The appliance is pre-set for normal operation. We recommend a temperature of -18°C.

- ▼ ● **To reduce the temperature:** Press the DOWN button ②.
  - ▲ ● **To increase the temperature:** Press the UP button ②.
- While you are entering the temperature, the **set temperature will flash** on the display.
  - When you press the temperature setting buttons for the first time, the *most recent setting* (known as the "*reference setting*") is displayed.
  - You can change the settings in increments of 1°C by briefly pressing the buttons again. If the buttons are held down the temperature setting will change faster.
  - The electronic controls will switch over automatically about 5 seconds after the last time you pressed the button, and the *actual* temperature in the freezer (known as the "*actual setting*") will be displayed.
  - The temperature can be set at between -14°C and -28°C.
- Whether you can obtain the lowest temperature depends on where the appliance is positioned (if it is located in an area with a high ambient temperature it will not reach the lowest temperature).

### Child-proof lock

fig. A1



The child-proof lock is designed to protect the appliance from being switched off accidentally.

- **Switching on the child-proof lock:** Hold down the audible warning on/off button ⑤ and then press the Superfrost button ④, and keep both buttons pressed simultaneously for approx. 3 seconds.
  - A double beep confirms your entry.
  - *The child-proof lock display* ⑥ *will come on.*
- **Switching off:** Press this key combination again; the display ⑥ will now go out.

## 2 Operation and control elements

### Temperature display

fig. A1

The *highest temperature of the frozen food* ① is displayed in normal operating mode.

**When the appliance is switched on for the first time** and while it is still warm, the display will contain *dashes* until the temperature falls below 0°C.

**-18**

**The display will flash:**

- if you change the temperature or
- if the temperature rises by several degrees, indicating cold loss, e.g. if you place fresh, "warm" food in the freezer or if you remove or re-pack frozen food the temperature may rise for a short time due to warm air flowing into the freezer. Once you have finished loading or re-packing, the electronics will automatically re-set the temperature to the most recent setting. Short-term rises in temperature will not affect the frozen food.
- If "F7" to "F5" appears in the display, the appliance has a fault. Consult the customer service department indicating the fault number displayed as this will tell the technician what kind of irregularity has occurred.

### Display brightness

Your appliance is delivered with the display brightness set to low.

When the door is opened or the temperature settings changed, the display automatically switches to bright for one minute, or as long as the alarm state lasts.

You can change the brightness if required, fig. A1:

- **To make display brighter:** Keep the audible warning on/off button pressed and press UP button ② (increase temperature) simultaneously.
- **To make display darker:** Keep the audible warning on/off button pressed and press DOWN button ② (reduce temperature) simultaneously.

### Audible warning signal

ALARM fig. A1



The audible warning signal helps to protect frozen food and to save energy.

- **The audible warning device is switched off** by pressing the audible warning button ⑤.
- It switches off automatically as soon as the temperature is low enough or
- the door is closed.

### Audible door alarm

- This sounds when the door has been left open for longer than about 60 seconds. The sound switch-off function is active as long as the door is left open. The alarm automatically switches back to standby when the door is shut.

### Audible/visual temperature alarm

- It always sounds if the freezer temperature is not low enough (dependent on the temperature setting).
- The *temperature display flashes* at the same time.

This can be caused by:

- warm, fresh food being placed in the freezer,
- too much warm air from the outside entering when re-arranging or removing frozen food.

The temperature display will continue to *flash* until the cause of the alarm has been rectified. It will then stop flashing and light up continually. The audible warning signal is now automatically *reset*.

### Power failure/"frost-control" display

fig. A1

If **nA** appears in the display, this means that the freezer temperature has risen too *high* during the last few hours or days due to a power failure. **GB**

Once the power is re-instated, the appliance will continue to operate at the most recent temperature setting.

- If you press the audible warning on/off button ⑤ whilst the display is reading **nA**, the *highest* temperature registered during the power failure will be displayed.

Check the quality of the food and its suitability for consumption in case it has become too warm or even defrosted.

The highest temperature will appear for approx. 1 minute. After that, the actual temperature in the freezer will re-appear. The display can be switched off by repeatedly pressing the audible warning on/off button.

### Lighting

This switches off automatically after the door has been opened for approx. 15 minutes. If it does not switch on when the door is opened briefly, but the temperature display is working, the bulb may be defective.

### Replacing the bulb:

- **Bulb data:** max. 25 W; current and voltage must agree with the details on the type plate. Only use bulbs of the same size. Bulb fitting: E 14.
- Switch off the appliance. **Disconnect from the mains or remove or unscrew the fuse.**
- Change the bulb behind the operating panel as illustrated.

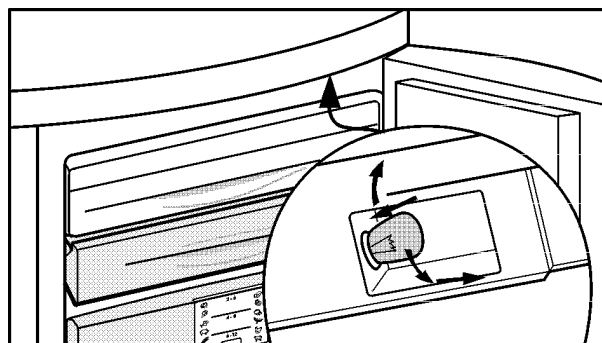

### 3 Superfrost, notes on freezing and storage

#### Superfrost

fig. A1

Fresh food should be frozen to the core as rapidly as possible. Frozen food can also be given a cold boost. This is provided by the "Superfrost" facility and ensures that the nutritional value, appearance and flavour of the food remain intact.

- The maximum amount of food which can be frozen in 24 hours is shown on the type plate ("Freezing capacity ... kg/24h"), fig. A2, pos. ④. This amount varies according to the model and climate rating.

#### Freezing with Superfrost

SUPER FROST



- Press the Superfrost button ④ briefly so that it lights up. The freezer temperature will decrease and the appliance will switch to the lowest temperature.
- For small amounts of frozen food, it is normally sufficient to switch on Superfrost 6 hours beforehand. For the *maximum* amount (see freezing capacity on the type plate) you will need to switch it on 24 hours beforehand.
- Then place the fresh food inside the freezer, preferably in the top drawers. If freezing the *maximum* quantity of food, do *not* use the drawers; instead, place the wrapped food directly on the shelves. Once the food is frozen you can load it into the drawers.
- The Superfrost function switches off **automatically**. Depending on the quantity of food placed in the freezer, this will normally be between 30 and max. 60 hours. The freezing process is now complete, the **Superfrost button will go dark**, and the freezer will switch back to normal energy-saving operation.

*Note:* When the Superfrost function is activated the appliance will be running at full capacity, so the refrigeration unit will sound slightly louder for a while.

You should *not* switch on the Superfrost function:

- when placing frozen food in the freezer;
- when freezing up to approx. 2 kg fresh food daily.

#### Notes on freezing and storage

- **Items suitable for freezing:** meat, game, poultry, fresh fish, vegetables, fruit, dairy products, bread, baked goods, pre-cooked meals.  
**Not suitable:** lettuce, radishes, grapes, whole apples and pears, fatty meat.
- **Pack frozen food** in standard freezer bags or reusable plastic, metal or aluminium containers.
- Do not allow fresh food which is to be frozen to come into contact with food already frozen. Always keep packs dry in order to avoid them sticking together.
- Always write the date and contents on the pack and do not exceed the stated storage time for the food. This prevents any risk of quality impairment.

- Pack food which you are freezing yourself in quantities appropriate to your household. To ensure that the food freezes right through quickly, the following quantities should not be exceeded per package:
  - fruit, vegetables: up to 1 kg;
  - meat: up to 2.5 kg.
- Blanch **vegetables** after washing and cutting them. (Add to boiling water for 2-3 minutes, remove and quickly cool down in cold water. If you blanch with a steamer or microwave oven, please observe the relevant operating instructions.)
- Do not salt or season fresh food or blanched vegetables before freezing. Only lightly salt and season other food. Some spices can alter their flavour intensity.
- Do not freeze bottles and cans which contain carbonated drinks as they might burst. Drinks can be cooled down quickly, but take the bottles out of the freezer compartment after an hour at the most.

- **Storage:** Each drawer and shelf can take up to 25 kg frozen food.
- If you want to use the maximum net capacity, you can remove the drawers and store items directly on the shelves.
- **Removing drawers:** Pull forward until the drawer stops and lift out.
  - If you have removed the drawers, *do not* cover the fan slits at the back, otherwise the freezer will not work properly.
- Always store identical food items together to avoid the door being open for unnecessarily long periods and to save energy.
- Do not exceed storage times given.

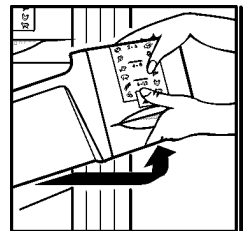

- **Thawing:** Only take out as much food as is immediately required for thawing. Cook food which has been thawed as quickly as possible.  
**Frozen food can be thawed in the following ways:**
  - in a conventional or fan oven
  - in a microwave oven
  - at room temperature
  - in the refrigerator: the cold given off by the frozen food is used for cooling the other food.
  - Flat portions of meat or fish can be cooked when partially thawed.
  - Vegetables can be cooked from frozen (in half the normal time).



# 4 Equipment

pre-cooked meals		2 - 6	
ice-cream		4 - 8	
fish		6 - 12	
pork		2	
vegetables			
fruit			

G

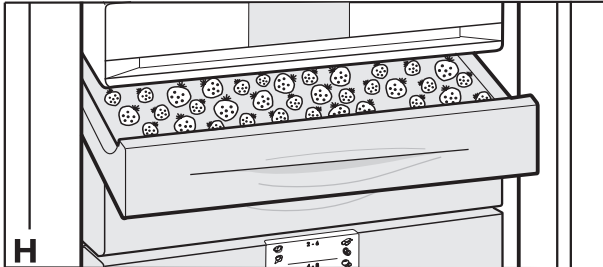

H

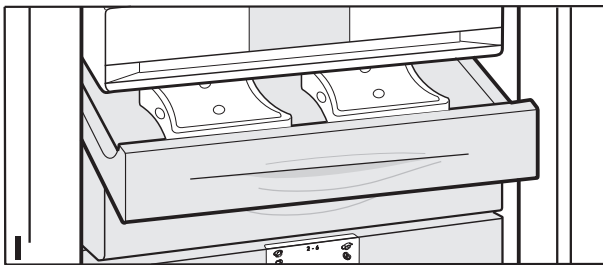

I

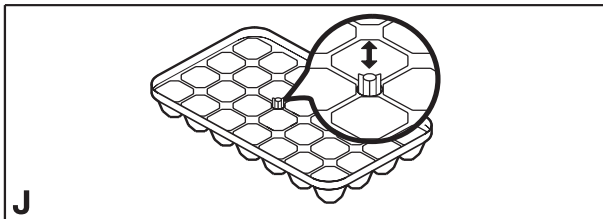

J

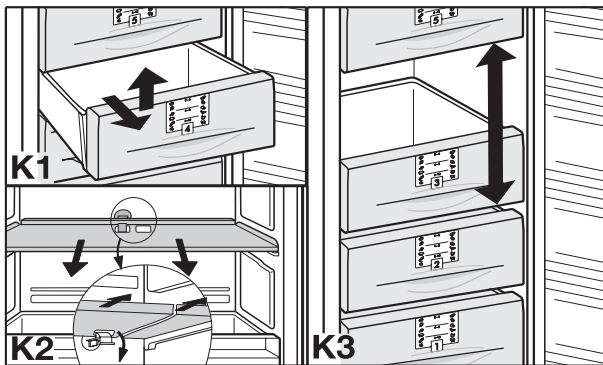

K1

K2

K3

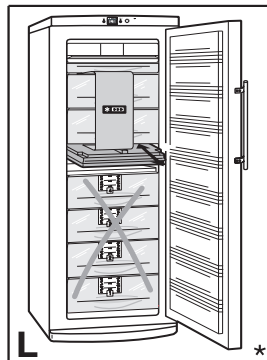

L

\*

## Information system\*

Use frozen food within the recommended period. The numbers between the symbols indicate the storage period in months for different kinds of frozen foods. Storage times given are guide times for food frozen at home. Whether or not the lower or upper value is applicable depends on the food quality and how it was processed prior to freezing. The lower values always apply to food with a high fat content.

## Freezer tray\*

This is used for gently freezing berries, herbs, vegetables and other small items and prevents them from sticking together. Items being frozen will largely retain their shape, and it will be easier to remove exactly the right quantity later on.

- Spread the items out loosely on the tray, fig. H.
- Freeze for 10 to 12 hours, then transfer to a freezer bag or container and put in a drawer.
- To defrost, spread the frozen items out loosely.

## Cold-storage accumulators\*

These prevent the temperature in the freezer from rising too quickly in the event of a power failure, thus preserving the quality of the food.

- To save space, you can freeze and store the cold-storage accumulators in the freezer tray, fig. I.
- To ensure maximum storage time in the event of a power failure, place the frozen cold-storage accumulators in the top freezer drawer on top of the food.

## Making ice-cubes

- Press the locking bolt downwards.
- Fill the ice-cube tray with water. Surplus water will flow through the drain hole.
- Push the locking bolt upwards.
- Place the ice-cube tray in the appliance and leave it to freeze.
- The ice-cubes can be removed from the tray by twisting or by holding upside down for a short time under running water.

## Vario-Space\*

- You can create a double-height space for **big items of frozen food** by removing a drawer and a shelf. This enables you to freeze such things as poultry or big pieces of meat without having to cut them up first, so they can be served "whole" afterwards, and to store other large items such as big gateaux or packs of ice.
- Example (figs. K1/2): Remove the 3rd and 4th drawers, press down the catch at the back underneath the shelf and slide the shelf out towards you. Replace the 3rd drawer and use to store your bulky items.
- To insert: slide shelf in and make sure it clicks into place.

## The Vario energy saving plate for running freezer at part capacity

is available as an accessory from your dealer. If you do not store much frozen food in your freezer you can use the Vario energy saving plate to cut your freezer's energy consumption by up to half.

- You can „switch off“ any number of drawers up to 5 (depending on model). At least 2 drawers are required for the refrigeration unit to work.

For more information see the instruction manual of the Vario energy saving plate.

\* Depending on model and options

## 5 Cleaning, energy savings

### Defrosting



The "No-frost" system automatically defrosts the appliance.

Any moisture arising collects on the evaporator and freezes, and is periodically defrosted and evaporated.

The automatic defrosting system keeps the freezer frost-free and eliminates the time and effort spent on defrosting manually.

### Cleaning



● **Before cleaning, always switch off the appliance. Disconnect from the mains or unscrew or remove the fuse.**

- Clean the outer walls, inside and equipment by hand with lukewarm water and a little detergent.
- Because of the risk of injury and damage to the appliance, steam cleaning equipment should not be used.
- Never use abrasive or scouring sponges. Do not use concentrated cleaning agents and never use abrasive or acid cleaners or chemical solvents.
- We recommend using a soft cloth and an all-purpose cleaner with a neutral pH value.
- Only use food compatible cleaning and care agents on the inside of the appliance.
- Do not allow cleaning water to penetrate the ventilation grilles or electrical components. Dry the appliance.
- Do not damage or remove the type plate on the inside of the appliance. It is very important for servicing purposes.

● The dust should be removed from the **refrigeration unit** and heat exchanger - metal grid at the back of the appliance - once a year. Dust deposits increase energy consumption.

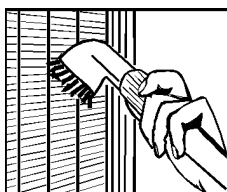

- Ensure that none of the wires or other components are dislodged, bent or damaged.
- Then connect/switch on the appliance, switch on "Superfrost" and start to insert the food to be frozen as the temperature drops.

If the appliance is to be **left switched off for any length of time**, empty the appliance, disconnect from the mains, clean as described above and leave the door open so as to avoid odours.

### Notes on energy saving

- Ensure that there is adequate space around the appliance for ventilation and air extraction.
- Avoid keeping the door open for too long.
- Store food logically. Do not exceed the storage period specified.
- Keep all food properly packed and covered so as to avoid its frosting up on the outside.
- Always allow hot food to cool to room temperature before placing in the appliance.
- Defrost frozen food in the refrigerator.
- Keep the appliance door shut in the event of a breakdown. This will delay the cold loss and will help to maintain the quality of the frozen food for longer.

## 6 Troubleshooting

Your appliance is designed and manufactured for a long life span and reliable operation.

If a malfunction nonetheless occurs during operation, check whether it is due to an operating error. Please note that even during the warranty period the resultant servicing costs in this case will have to be borne by the owner. You may be able to rectify the following faults by checking the possible causes yourself:

Malfunction      Possible cause and remedy

Appliance does not work, the display is off

- Is the appliance switched on properly?
- Is the mains plug properly inserted in the socket?
- Is the socket fuse intact?

**The lighting does not come on**

- Is the appliance switched on?
- Has the door been open for more than 15 minutes?
- The bulb is defective. Check the bulb as described in "Lighting" and change if necessary.

Loud running noise

- Is the appliance standing firmly on the floor, or does the compressor cause nearby items of furniture or objects to vibrate?

If necessary, move the appliance slightly, align by adjusting the adjustable feet, or move bottles and containers apart.

- *Bubbling noises* are normal. These are caused by the refrigerant flowing round the refrigerant circuit.

A short *clicking sound*: This will be heard whenever the refrigeration unit (the motor) switches on or off automatically.

*Motor noise*: This will be slightly louder for a brief period when the refrigeration unit switches on. The refrigerating capacity will increase when the Superfrost function is activated, fresh food has just been placed in the appliance or the door has been left open for a while.

The alarm sounds, the temperature is not cold enough

- Have you put too much fresh food into the freezer *without* activating Superfrost? (See "Superfrost")
- Does the door close properly?
- Is the appliance sufficiently well ventilated? Clear ventilation grilles if necessary.
- Is the ambient temperature too hot? (See "Safety regulations")
- Has the appliance been opened too often or left open too long?
- If applicable, wait until the appliance reaches the required temperature itself.

**nF** appears in the display

- There has been a power failure; proceed as described in "Power failure/"frost-control" display".

The outside of the appliance may feel warm in places

- That is quite normal. The heat from the cooling circuit is used to avoid the formation of condensate.

Customer service and type plate

If none of the above causes apply and you cannot rectify the fault yourself, or if the temperature display reads "**F1**" to "**F5**", this means that there is a fault.

Please contact your nearest customer service department (see enclosed list for addresses). Give the **fault number displayed**, together with the

**type designation** ①,  
**service number** ② and  
**appliance number** ③

as given on the type plate, fig. **A2**, so as to ensure rapid, accurate servicing. The type plate is located inside the freezer compartment on the left-hand side.

Leave the appliance shut until the customer service engineer arrives so as to prevent any further cold loss.





# Instructions for installation and modification

## Dimensions

The external dimensions of the appliance can be seen on the illustration at the back (fig. **S**) and in the table below.

Gross capacity of appliance (l) (see type plate)	height <b>H</b> (mm)
<b>190</b> (20..)	1250
<b>235 / 236</b> (24..)	1447
<b>289 / 282</b> (29..)	1644
<b>325 / 327</b> (33..)	1841

## Installation instructions

- Do not install models *without* side-wall heating side-by-side with another refrigerator or freezer. This is important to prevent condensation and consequential damage from it.
- Models *with* side-wall heating (for example **GSND**) are designed for side-by-side installation; they are designed for combination with a refrigerator. Attachment instructions are supplied in the accessories bag.

## Changing over door hinges

Fig. **T**: The door hinges can be changed from one side to the other if required.

- With the door open, lever out plinth panel ① with a screwdriver and remove.
- Lever out cover ② with a screwdriver.  
Close door.
- Unscrew screw M5 ③.
- Pull hinge component ④ with hinge pin ⑤ out from underneath and remove.
- Open door, tilt out from underneath and remove, taking care not to lose the spacer.
- Transfer all hinge components onto the other side:
  - Unscrew top hinge pin ⑥ and screw in on opposite side. Use the hexagon socket on the spanner provided.
  - Bottom: Using a screwdriver, remove the spacer ⑦ and replace on the other side.
- Re-attach the door:
  - Remove plugs ⑧ from the door mounting points and replace on the other side.
  - Suspend door with spacer in hinge pin ⑥, close door.
  - Rotate hinge component ④ by 180°, remove hinge pin ⑤, turn by 180° and replace. Mount both parts in the hinge ⑨: slide the pin into the door mounting through the hinge, tilt in the hinge component, slide up and attach with screw ③.
- Align the door *flush* with the body of the appliance using the slot on the hinge ⑨, then tighten screw ③.
- Attach the plinth panel ① and click into place by pressing.
- With door open, insert the cover ② in the plinth panel at the front and click into place at the back.
- Transfer\* **door handle** ⑩ and plugs ⑪. With the door open, carefully lift out the pressure plates\* ⑫ at the front and slide away; unscrew handle.  
Reassemble in reverse order: replace the pressure plates and click into position.

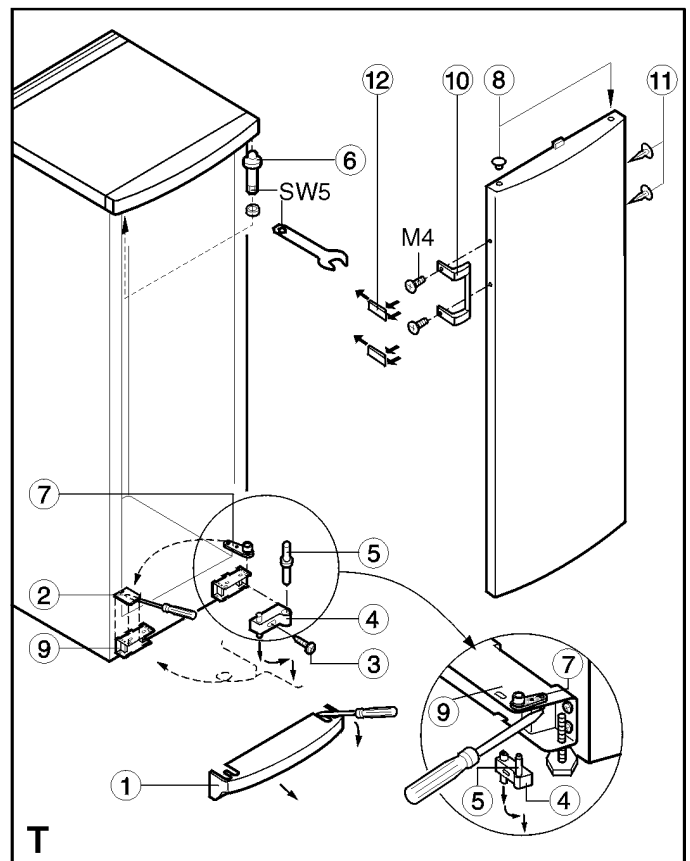
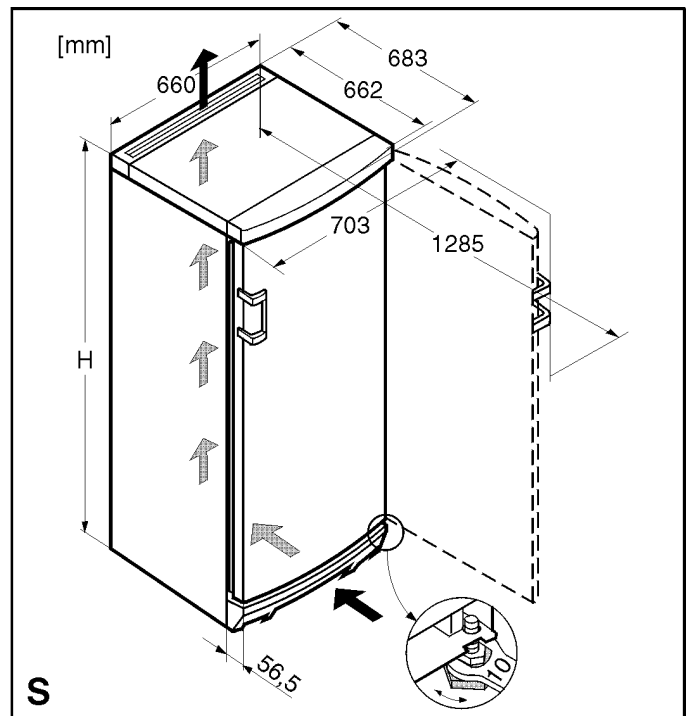

All types and models are subject to continuous improvement and the manufacturer therefore reserves the right to make modifications in the shape, equipment and technology.